



FOAM PROPORTIONING SYSTEM

First and only local manufacturer having **FM Certificate** in TÜRKİYE

- Bladder Tank Proportioning System •
- Ratio Controller •
- Foam Concentrate Control Valve •
- Foam Concentrate •



Certificate of Compliance

This certificate is issued for the following:

Low Expansion Foam Systems

For Use with HD AFFF 3F-C6 and HD AR-AFFF 3x3-C6 Aqueous Film-Forming Foam Concentrates

Fire Protection Monitor Assemblies

Models: 3A WM1C, 3A WM2S, 3A WM3C, 3A WM4B

Firefighting Nozzles for use with Monitor Assemblies

Models: Model 3A MN1, Model 3A MN2

Prepared for:

3A Köpüklü Yangın Korunum Sistemleri San. ve Tic. Ltd. Şti.
Kultur Mahallesi, Efil Sokak No:2/414
Tatvan, Bitlis 13200
Türkiye

FM Approvals Class: 5130, 1421, 5511

Approval Identification: PR461429

Approval Granted: 28 June 2024

To verify the availability of the Approved product, please refer to www.approvalguide.com

Said Approval is subject to satisfactory field performance, continuing Surveillance Audits, and strict conformity to the constructions as shown in the Approval Guide, an online resource of FM Approvals.



Member of the FM Global Group

David B. Fuller
VP, Manager – Fire Protection
FM Approvals
One Technology Way
Norwood, MA 02062



Önsöz

3A Köpüklü Yangın Korunum Sistemleri San. ve Tic. Ltd. Şti. 2024 yılında kuruldu. Kuruluş amacımız yangın sektöründe özellikle endüstriyel tesislerin korunması konusunda çalışmaktır.

Temel amacımız, endüstriyel yangın tehlikelerine doğru ve akılcı çözümler üretmektir. Endüstriyel yangın tehlikelerine uygun çözümler üretirken, ulusal ve uluslararası kuralları uygulayarak bu kuralların gerektirdiği kalitede ve onaylara sahip ürünleri kullanarak çözüm üretmektir.

Temel hedefimiz sorun değil çözüm üretmektir. Bu yönü ile 3A Yangın, yetişmiş kadrosu, yurt dışı çözüm ortakları ve özel çözüm yöntemleri ile sektördeki yerini almıştır. Deneyimli kadrosu ile kendi içinde iş bölümü yapmış olup, malzeme satışı, sistem dizaynı ve projelendirme, taahhüt, teknik servis hizmetlerini farklı departmanları ile vermektedir.

3A Köpüklü Yangın Korunum Sistemleri San. ve Tic. Ltd. Şti. Müşteri memnuniyetini, sürekli gelişmeyi, kaliteyi, ekip çalışmasını, sosyal sorumluluğu, profesyonel yönetim anlayışını, teknolojik gelişmelere uygunluğu ve paylaşımı esas alan bir anlayışla sektöründe lider bir kuruluş olmayı kendine "Vizyon" edinmiştir.

Ayrıca belirlemiş olduğumuz bu vizyon çerçevesinde müşterilerimize, çalışanlarımıza, ülkemize kaynak ve değer yaratan örnek bir kuruluş olmayı kendimize "Misyon" edindik.

TECHNICAL DATA	
TANK MOUNTING TYPE	Vertical or Horizontal
CONCENTRATE STORAGE CAPACITY	For Vertical Tank 140 liters to 7500 liters (36 TO 2000 Gallon (US)) For Horizontal Tank 140 liters to 15000 liters (36 to 4000 Gallon (US))
MAXIMUM WORKING PRESSURE	12 Bar (175PSI)
FLOW	Refer Ratio Controller Product Data Sheet-A2103103
VESSEL CONSTRUCTION	Carbon Steel as per ASME Code Section VIII Div 1, for unfired pressure vessels
BLADDER	Buna-N
EXTERNAL PIPING	Water side: Carbon Steel Seamless Pipe Sch.40 Foam Concentrate side: Stainless Steel Sch.40
RATIO CONTROLLER	Wafer type with Stainless Steel 304/CF8 standard supply Optional: Stainless Steel 316/CF8M or Bronze
VENT AND DRAIN	Ball valve
APPROVALS	FM Approved
OPTIONAL SUPPLY	Refer to page 3
FINISH	Red RAL 3001
ORDERING INFORMATION	Specify: 1) Tank type, vertical or horizontal 2) Storage capacity 3) Model number, size of ratio controller with flow and pressure 4) Type of foam concentrate to be used and percentage of induction required 5) Optional items 6) FM Approval Requirement

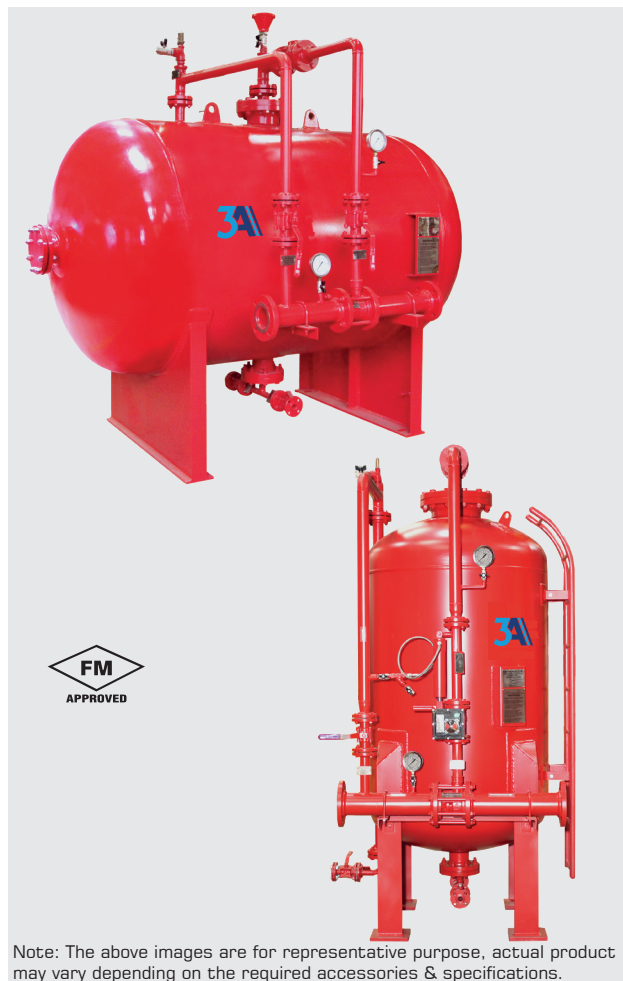

Note: The above images are for representative purpose, actual product may vary depending on the required accessories & specifications.

APPLICATION

The Bladder Tank Foam Proportioning System utilises water pressure to inject foam concentrate into water supply and automatically proportions foam concentrate over wide range of flow and pressure, with very low pressure drop. This system does not require a foam concentrate supply pump.

SPECIFICATION

The Bladder Tank Foam Proportioning Systems are available with vertical and horizontal bladder tanks. The carbon steel tanks are designed and constructed in accordance with ASME Code Section VIII Div.1 for unfired pressure vessels.

The maximum working pressure is 12 Bar (175 PSI). The vertical tank assembly is supported by legs welded to tank with provision for anchoring. The horizontal tanks are supported by two saddles welded to the tank and drilled for anchoring. Tank is provided with lifting lugs.

The system is supplied with pressure vessel, bladder, fill and drain valve for water and foam concentrate, ratio controller and vent valve.

Ladder and sight gauge assembly are supplied as optional items on request.

All valves are labeled showing normal working position and function. All tanks are oversized for allowing thermal expansion of the foam concentrate, if any.

PRINCIPLE OF OPERATION

The instructions for filling are provided with the equipment. Once the main water flow is established and water inlet and foam outlet valves are opened, the water enters the area between vessel wall and bladder, applying pressure to the bladder. The foam concentrate is forced out of the bladder through the foam concentrate outlet pipe and into the ratio controller through metering orifice. The concentrate pressure and water inlet pressure at ratio controller will be same, as the main water supply pressure is utilised to expel the foam from the bladder. The water flowing through the ratio controller jet creates a low pressure area for foam concentrate. This injects the concentrate in to the ratio controller through an accurate sized orifice proportioned to water venturi. This ensures correct proportioning over a wide range of flow condition.

The bladder tank proportioning system operates on same principle as that of a balance pressure proportioning system. In bladder system, the bladder is used as diaphragm to separate the water and foam concentrate within the tank. The foam concentrate is injected into the ratio controller utilising water pressure.

The system is also supplied with foam concentrate control valve as an optional item. The valve allows concentrate flow only when minimum of 2.1 kg/sq.cm. water pressure is established in the system. For pressure drop and flow characteristics refer catalogue of ratio controller.

3A

SELECTION OF HORIZONTAL/VERTICAL BLADDER TANKS

Advantages of Horizontal bladder tanks

- (i) Better stability than vertical tank in earthquake prone area
 - (ii) Easier to refill than vertical tanks
 - (iii) Easy to transport, store and install
 - (iv) Large Capacity
- ### Advantages of Vertical bladder tanks
- (i) Require less floor space than horizontal tanks

INSTALLATION, INSPECTION AND MAINTENANCE

An installation, inspection and maintenance manual is packed with each unit. The manual provides detail schematic, initial procedure, inspection and maintenance procedures. The instruction manual must be read carefully and followed during installation and commissioning of the system.

After few initial successful tests an authorised person must be trained to perform inspection and testing of the system. It is recommended to carry out physical inspection of the system regularly, the inspector should verify that no damages have taken place to any component and all the valves are in their proper position as per the system requirement. The system should be fully tested at least once in a year and in accordance with applicable NFPA code or in accordance to the guidelines of the organisation having local jurisdiction.

Do not turn off the system or any valve to repair or test the system, without placing a roving Fire Patrol in the area covered by the system. The patrol should continue until the system is put back in service. Also inform the local security personnel and the control room so that a false alarm is not signalled.

CAUTION

- 1) Do not weld on the tank as it may damage the bladder fitted inside the tank.
- 2) Release pressure before an inspection and maintenance of the system.
- 3) Sight gauge is not pressure tight, so before taking concentrate level reading, tank pressure must be released.
- 4) The bladder tank is to be installed under a shed to avoid direct sunlight on the equipment.
- 5) While designing a foam system, step shall be taken to allow for removal of the internal centre tube(s). The centre tubes are full length and/or height of the bladder tank.
- 6) ASME Code may require over pressure protection before pressurising the system. 3A does not supply an over pressure relief valve with the tanks. It shall be the owner's responsibility to provide over pressure protection for the tank in accordance to ASME Code.
- 7) Foam concentrate filling procedure must be followed. Incorrect filling procedure may damage the bladder. 3A product have limited warranty and incorrect fill procedure will void the warranty.

NOTE

- 1) The foam concentrate is to be filled in the bladder very carefully to avoid rupture of bladder. The filling guidelines provided with the equipment must be strictly adhered.
- 2) Air supply with regulator (0 to 1.0 kg/sqcm) required during filling procedure, to be arranged by installer / user.
- 3) Water supply at 0-1.5 kg/sqcm required for tank filling during commissioning, to be arranged by installer / user.
- 4) Concentrate fill pump need to be arranged by installer / user.
- 5) A minimum length of 5 (five) times the pipe diameter of unobstructed straight pipeline should be provided at the inlet and outlet of the ratio controller, where pipe diameter is the nominal size of the ratio controller.
- 6) FM Approval of Bladder tank is applicable only if FM Approved Bladder tank, Ratio Controller, Foam Concentrate and Discharge Devices are installed.
- 7) Foam Concentrate Control Valve is requirement for FM Approval. Hence Tanks will be FM Approved.
- 8) FM Approved Bladder tank permits maximum two Ratio Controllers.
- 9) Each tank is designed & tested for specific type of foam concentrate, hence specify in order the concentrate type to be used.

OPTIONAL SUPPLY

- Sight gauge with shut off and drain valve (glass or polycarbonate material)
- Ladder
- Pressure Gauges
- Concentrate control valve
- Filling kit with foam concentrate filling pump
- Stainless steel pipe for water supply side
- Stainless steel pipe & valve standard supply SS304/CF8. Optional is SS316/CF8M or SS316L/CF3M
- Painting as per specific requirement

- Seismic designed tanks
- Custom design for higher rating, material and dimension
- Internal surface is epoxy painted as standard supply, or any other paint as per customer requirement
- Ratio controller material Bronze, Stainless steel CF8M
- Relief valve is not included in standard supply it is optional as per specific customer requirement
- Corrosion allowance.

RELIEF VALVE (OPTIONAL SUPPLY)

- (i) Thermal Relief valve
- (ii) Full flow, as per ASME
- (iii) Full flow, ASME "U" Stamped

LISTING & APPROVAL

- 1) Bladder tank proportioning system is FM Approved
- 2) Listing and Approval is valid only when used in the manner as outlined in the applicable Listing and Approval.
- 3) Foam Concentrate Control Valve is standard supply with FM Approved Bladder tank.

SHIPPING DETAILS

- i) All the tank openings will be plugged for shipping.
- ii) All pre-piped pipes, valves, pressure gauges, sight gauge etc will be packed separately for shipping.
- iii) Tank will be mounted on pallet with crate all over as standard packing system of 3A For any custom packing requirement contact 3A Sales.

VERTICAL BLADDER TANK WITH SINGLE RATIO CONTROLLER

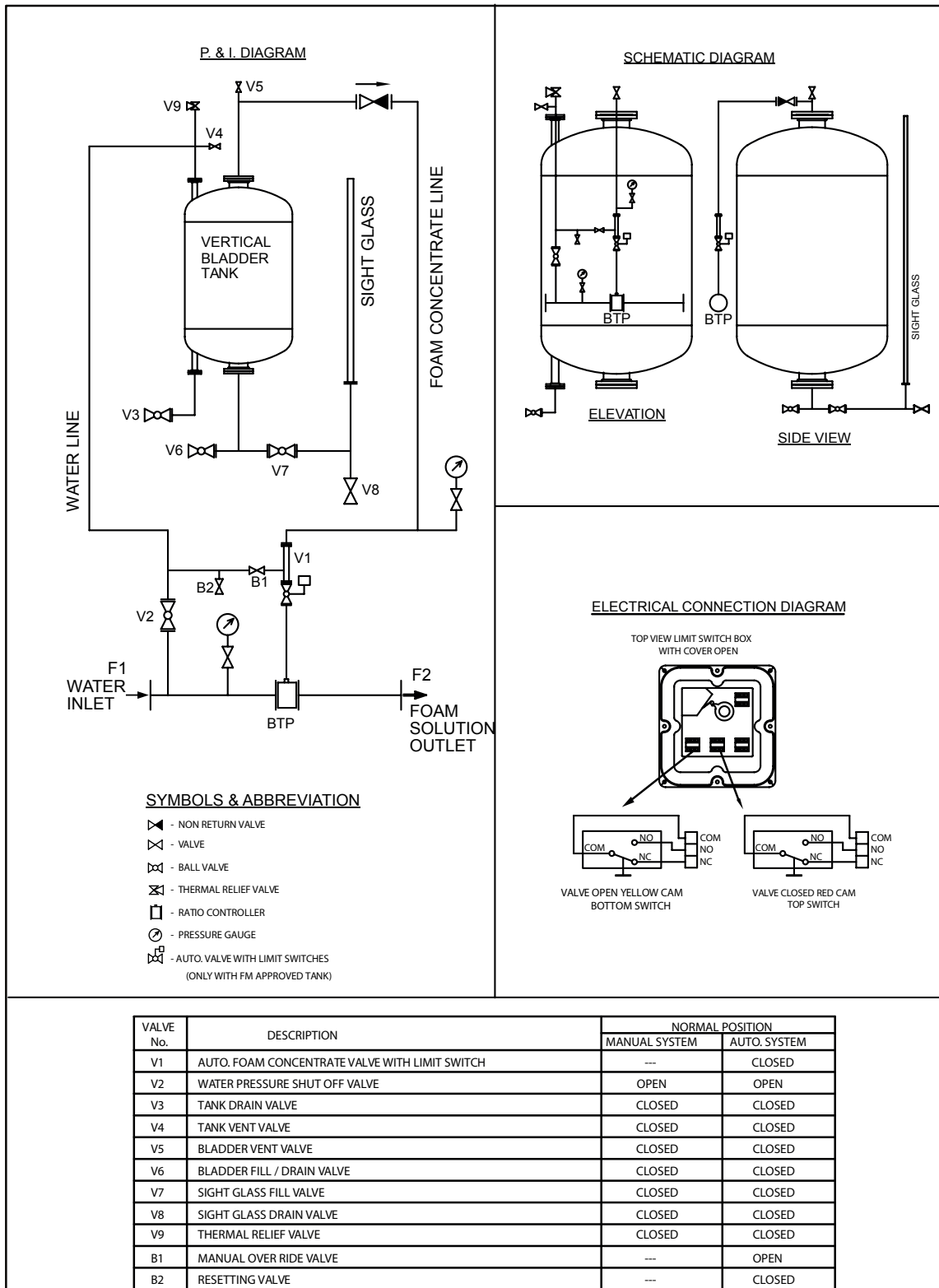

VERTICAL BLADDER TANK WITH TWO RATIO CONTROLLERS

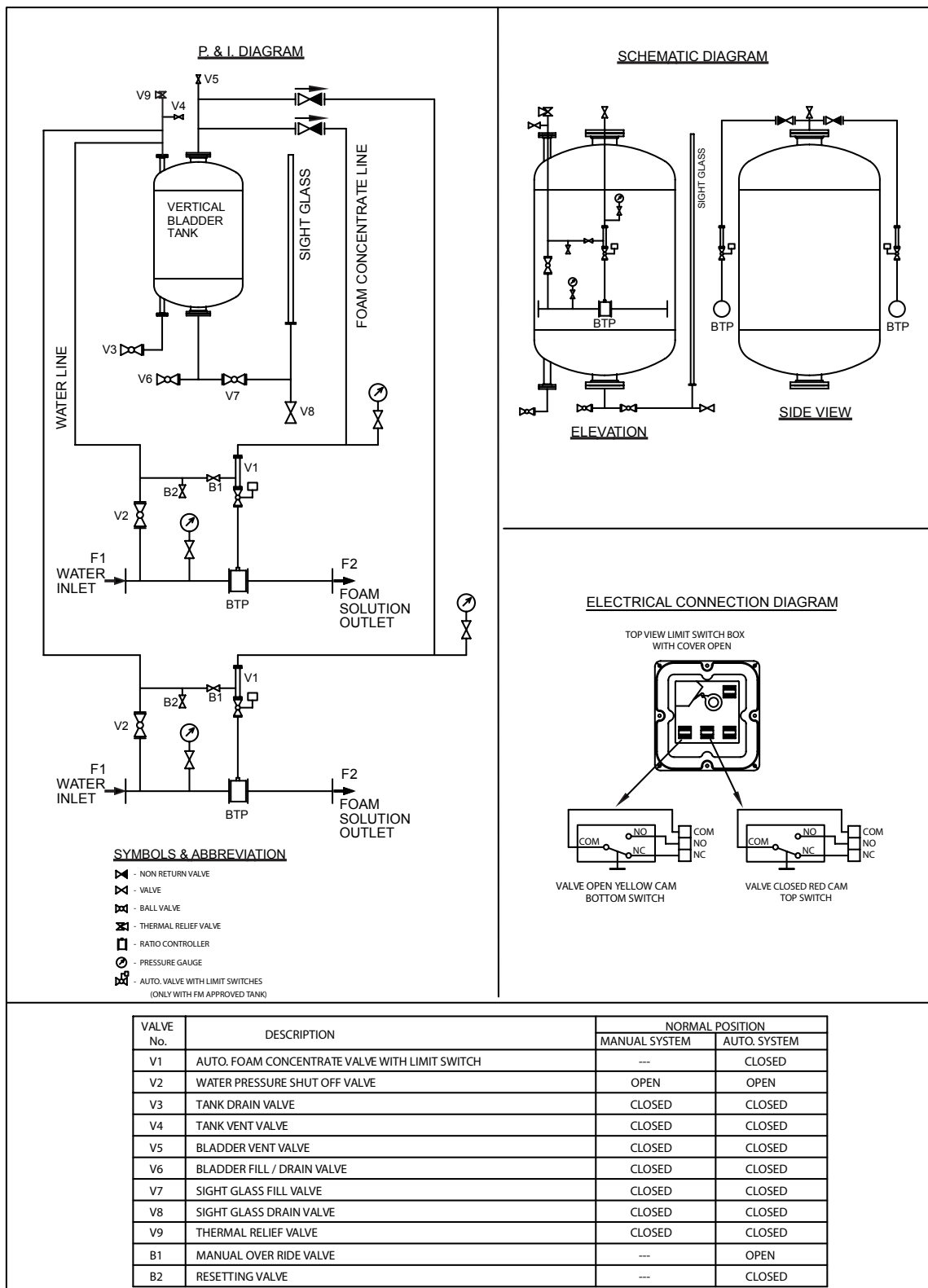

HORIZONTAL BLADDER TANK WITH SINGLE RATIO CONTROLLER

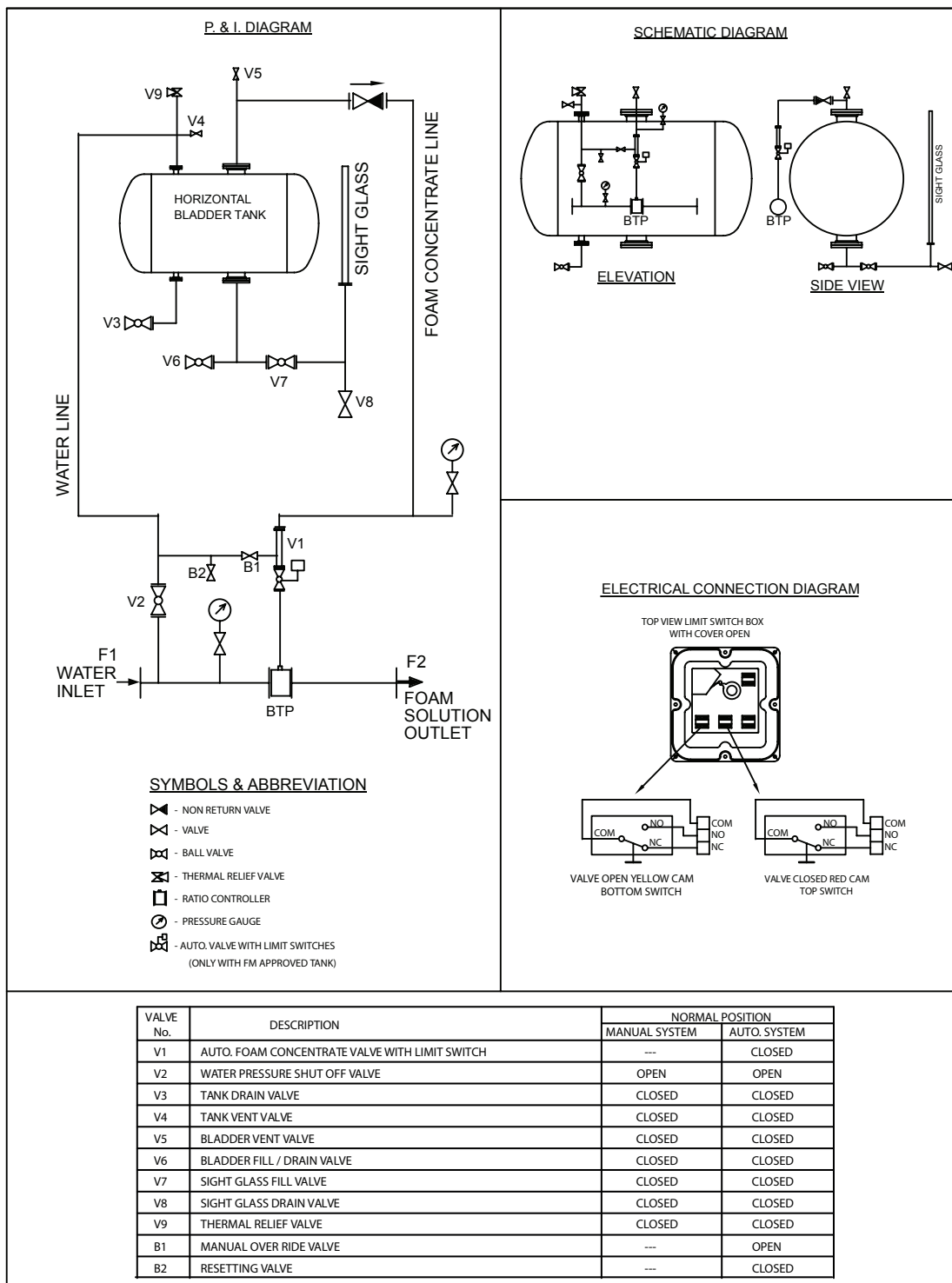

HORIZONTAL BLADDER TANK WITH TWO RATIO CONTROLLER

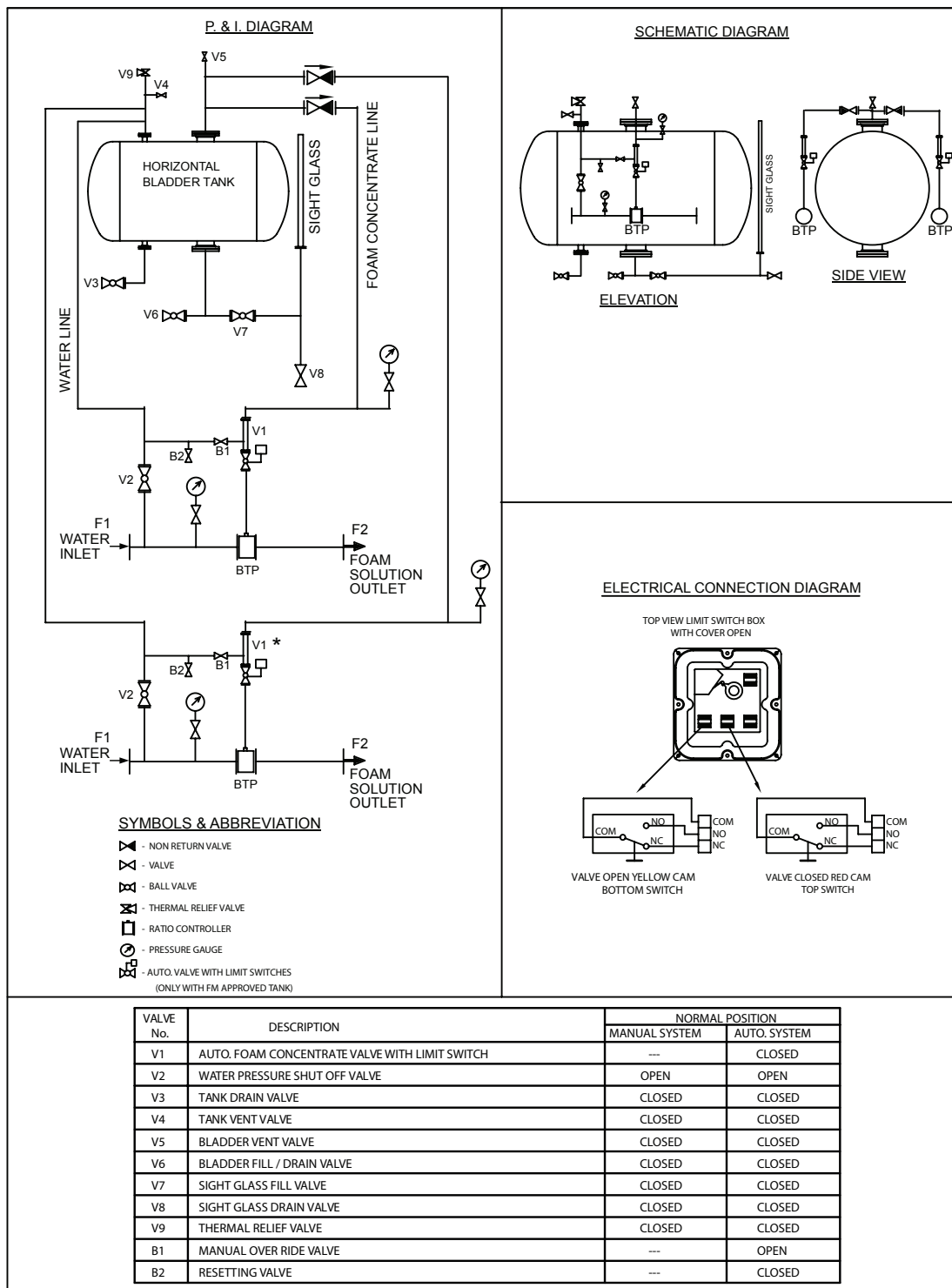

VERTICAL BLADDER TANK

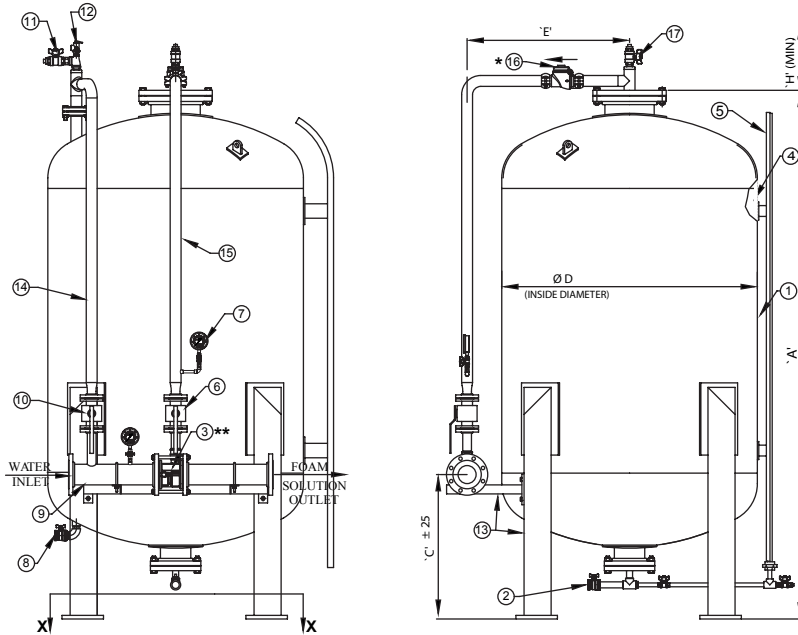

WITHOUT CONCENTRATE CONTROL VALVE

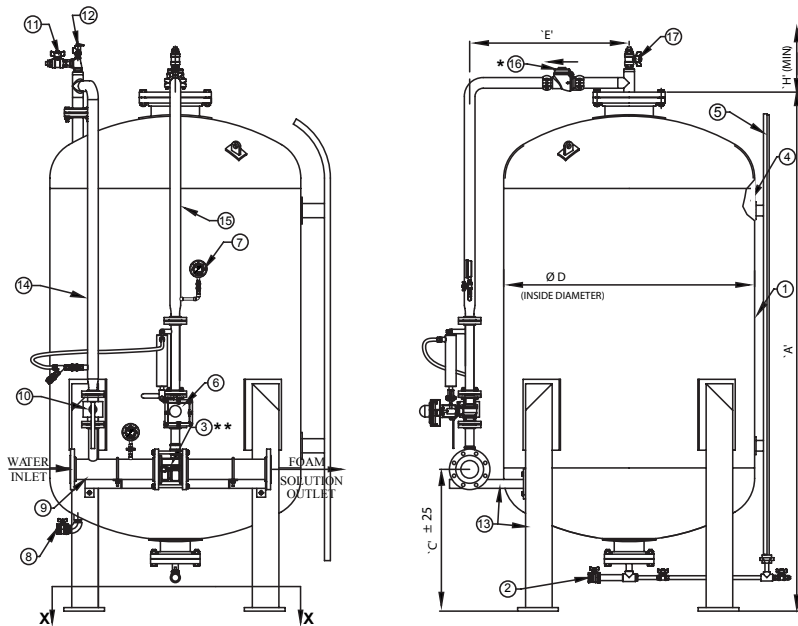

WITH CONCENTRATE CONTROL VALVE

SR. NO.	DESCRIPTION	MATERIAL SPECIFICATION
1	TANK	SA 516 GR. 70 (OR EQUIVALENT)
2	BLADDER FILL / DRAIN VALVE	BRASS
3	RATIO CONTROLLER	SS 304 / BRONZE/ SS316
4	BLADDER	BUNA-N
5	SIGHT GLASS	POLYCARBONATE
6	FOAM CONC. SHUT OFF VALVE	SS 304
7	PRESSURE GAUGE	STD. 0 TO 300 PSI
8	TANK DRAIN VALVE	BRASS
9	SPOOL PIECE	A106 SEAMLESS, SCH. 40
10	WATER SHUT OFF VALVE	SS 304
11	TANK VENT VALVE	BRASS
12	TANK SAFETY VALVE (THERMAL)	BRASS
13	SADDLE/ ANGLE LEGS SUPPORT	C.S.
14	WATER INLET LINE	A106 SEAMLESS, SCH. 40
15	FOAM CONCENTRATE LINE	SS 304, SCH. 40
16	CHECK VALVE	SS 304
17	BLADDER VENT VALVE	BRASS

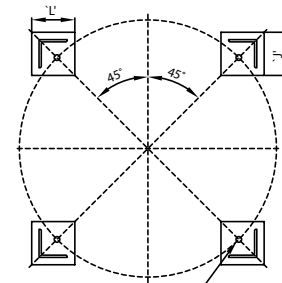

SECTION - 'X-X'

SELECTION OF FOAM CONCENTRATE CONTROL VALVE FOR HORIZONTAL & VERTICAL BLADDER TANK

3A RATIO CONTROLLER	FOAM CONCENTRATE CONTROL VALVE SIZE
65 NB	25 NB
80 NB	40 NB
100 NB	40 NB
150 NB	50 NB
200 NB	50 NB

* GROOVED - STANDARD SUPPLY, FLANGED - OPTIONAL
 ** WAFER TYPE STANDARD SUPPLY, FLANGED - OPTIONAL
 NOTE: CONCENTRATE CONTROL VALVE IS MANDATORY WITH FM APPROVED PRODUCT

CAPACITY & DIMENSIONAL CHART FOR VERTICAL BLADDER TANK

CAPACITY		Ø D (I.D.)	A	C	E	G	H (MIN.)	J	L	N
LITERS	GALLONS									
140	36	500	1418	525	500	462	1250	150	150	Ø 25
150	38	500	1466	525	500	462	1250	150	150	Ø 25
200	53	600	1423	575	500	560	1250	150	150	Ø 25
250	66	600	1618	575	500	560	1450	150	150	Ø 25
300	75	600	1811	575	500	560	1640	150	150	Ø 25
350	92	600	2006	575	500	560	1835	150	150	Ø 25
400	100	600	2200	575	500	560	2030	150	150	Ø 25
450	120	750	1790	625	580	710	1625	200	200	Ø 25
500	135	750	1915	625	580	710	1750	200	200	Ø 25
550	145	750	2039	625	580	710	1875	200	200	Ø 25
600	150	750	2164	625	580	710	2000	200	200	Ø 25
650	175	850	1947	675	625	810	1780	200	200	Ø 25
700	200	850	2044	675	625	810	1875	200	200	Ø 25
750	200	850	2141	675	625	810	1975	200	200	Ø 25
800	215	850	2237	675	625	810	2070	200	200	Ø 25
850	225	850	2334	675	625	810	2165	200	200	Ø 25
900	240	850	2431	675	625	810	2265	200	200	Ø 25
950	250	850	2528	675	625	810	2360	200	200	Ø 25
1000	265	1000	2112	750	700	960	1950	200	200	Ø 30
1100	290	1000	2252	750	700	960	2090	200	200	Ø 30
1200	300	1000	2392	750	700	960	2230	200	200	Ø 30
1300	325	1000	2532	750	700	960	2370	200	200	Ø 30
1400	350	1000	2672	750	700	960	2510	200	200	Ø 30
1500	375	1000	2813	750	700	960	2650	200	200	Ø 30
1600	400	1000	2953	750	700	960	2790	200	200	Ø 30
1700	450	1000	3093	750	700	960	2930	200	200	Ø 30
1800	475	1200	2502	800	800	1160	2330	230	230	Ø 30
1900	500	1200	2599	800	800	1160	2430	230	230	Ø 30
2000	530	1200	2696	800	800	1160	2525	230	230	Ø 30
2200	580	1200	2891	800	800	1160	2720	230	230	Ø 30
2400	600	1200	3085	800	800	1160	2915	230	230	Ø 30
2600	700	1200	3280	800	800	1160	3110	230	230	Ø 30
2800	750	1200	3474	800	800	1160	3300	230	230	Ø 30
3000	800	1400	2927	800	900	1370	2750	230	230	Ø 30
3250	850	1400	3106	800	900	1370	2930	230	230	Ø 30
3500	900	1400	3284	800	900	1370	3110	230	230	Ø 30
3750	1000	1400	3463	800	900	1370	3290	230	230	Ø 30
4000	1050	1400	3642	800	900	1370	3465	230	230	Ø 30
4250	1100	1600	3146	800	1000	1500	2975	300	300	Ø 30
4500	1200	1600	3283	800	1000	1500	3110	300	300	Ø 30
4750	1250	1600	3419	800	1000	1500	3250	300	300	Ø 30
5000	1300	1600	3556	800	1000	1500	3385	300	300	Ø 30
5250	1400	1600	3693	800	1000	1500	3525	300	300	Ø 30
5500	1450	1725	3431	800	1060	1640	3255	300	300	Ø 30
5750	1500	1725	3548	800	1060	1640	3370	300	300	Ø 30
6000	1600	1725	3666	800	1060	1640	3490	300	300	Ø 30
6250	1650	1725	3784	800	1060	1640	3610	300	300	Ø 30
6500	1700	1725	3901	800	1060	1640	3720	300	300	Ø 30
6750	1800	1725	4019	800	1060	1640	3850	300	300	Ø 30
7000	1850	1725	4137	800	1060	1640	3960	300	300	Ø 30
7250	1900	1725	4254	800	1060	1640	4080	300	300	Ø 30
7500	2000	1725	4372	800	1060	1640	4200	300	300	Ø 30



HORIZONTAL BLADDER TANK

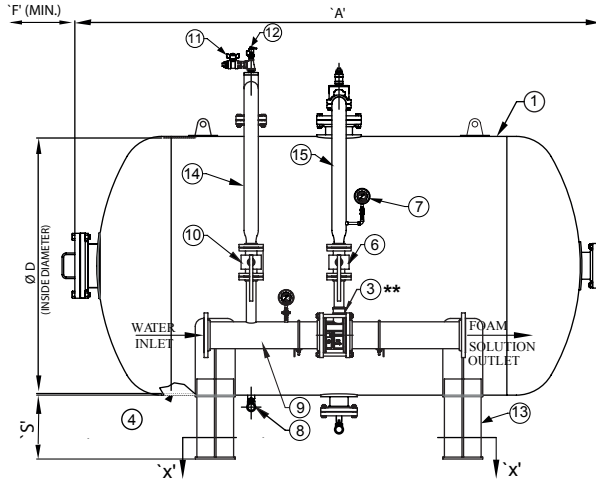

WITHOUT CONCENTRATE CONTROL VALVE

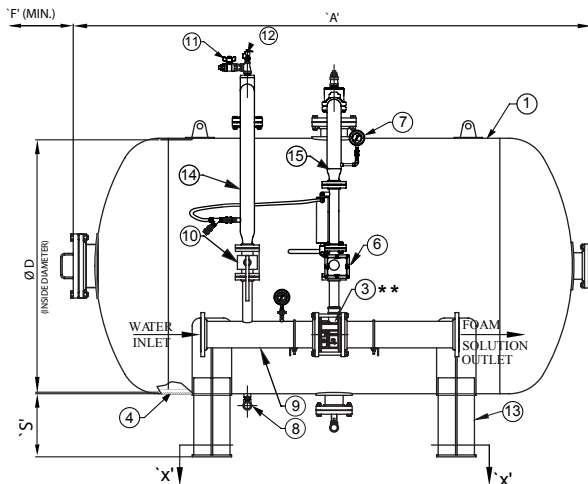
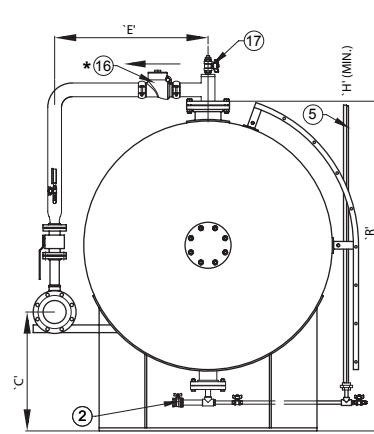

WITH CONCENTRATE CONTROL VALVE

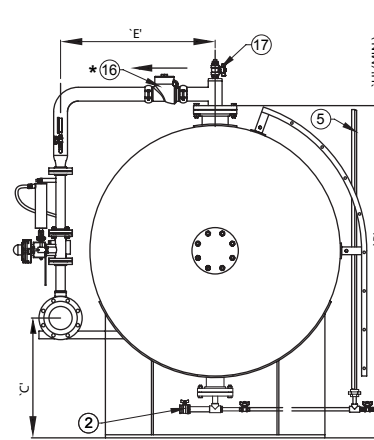

SR.NO.	DESCRIPTION	MATERIAL SPECIFICATION
1	TANK	SA 516 GR. 70 (OR EQUIVALENT)
2	BLADDER FILL/ DRAIN VALVE	BRASS
3	RATIO CONTROLLER **	SS 304 / BRONZE / SS 316
4	BLADDER	BUNA-N
5	SIGHT GLASS	POLYCARBONATE
6	FOAM CONC. SHUT OFF VALVE	SS 304
7	PRESSURE GAUGE	STD. 0 TO 300 PSI
8	TANK DRAIN VALVE	BRASS
9	SPOOL PIECE	A106 SEAMLESS, SCH. 40
10	WATER SHUT OFF VALVE	SS 304
11	TANK VENT VALVE	BRASS
12	TANK SAFETY VALVE (THERMAL)	BRASS
13	SADDLE/ ANGLE LEGS SUPPORT	C.S.
14	WATER INLET LINE	A106 SEAMLESS, SCH. 40
15	FOAM CONCENTRATE LINE	SS 304, SCH. 40
16	CHECK VALVE	SS 304
17	BLADDER VENT VALVE	BRASS

* GROOVED - STANDARD SUPPLY, FLANGED - OPTIONAL

** WAFER TYPE STANDARD SUPPLY, FLANGED - OPTIONAL

NOTE: CONCENTRATE CONTROL VALVE IS MANDATORY WITH FM APPROVED PRODUCT

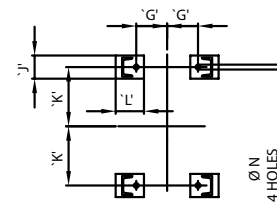

SECTION - 'X-X'
FOUNDATION PLAN
(200 L TO 1700 L)

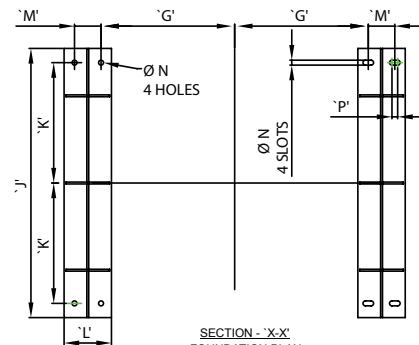

SECTION - 'X-X'
FOUNDATION PLAN
(1800 L TO 15000 L)

CAPACITY & DIMENSIONAL CHART FOR HORIZONTAL BLADDER TANK

CAPACITY		Ø D (I.D.)	A	C	E	F (MIN)	G	H (MIN)	J	K	L	M	N	P	R	S
LITERS	GALLONS															
200	53	600	1146	550	500	1250	120	875	90	230	110	-	Ø19	-	1142	400
250	66	600	1341	550	500	1445	215	875	90	230	110	-	Ø19	-	1142	400
300	75	600	1535	550	500	1640	315	875	90	230	110	-	Ø19	-	1142	400
350	92	600	1730	550	500	1835	410	875	90	230	110	-	Ø19	-	1142	400
400	100	600	1924	550	500	2030	510	875	90	230	110	-	Ø19	-	1142	400
450	120	750	1519	575	580	1610	260	1125	120	245	130	-	Ø19	-	1293	400
500	135	750	1644	575	580	1735	320	1125	120	245	130	-	Ø19	-	1293	400
550	145	750	1768	575	580	1860	385	1125	120	245	130	-	Ø19	-	1293	400
600	150	720	1893	575	580	1985	445	1125	120	245	130	-	Ø19	-	1293	400
650	175	850	1678	625	625	1770	300	1230	120	310	140	-	Ø19	-	1394	400
700	185	850	1775	625	625	1870	350	1230	120	310	140	-	Ø19	-	1394	400
750	200	850	1872	625	625	1965	400	1230	120	310	140	-	Ø19	-	1394	400
800	215	850	1968	625	625	2060	445	1230	120	310	140	-	Ø19	-	1394	400
850	225	850	2065	625	625	2155	495	1230	120	310	140	-	Ø19	-	1394	400
900	240	850	2162	625	625	2255	540	1230	120	310	140	-	Ø19	-	1394	400
950	250	850	2259	625	625	2350	590	1230	120	310	140	-	Ø19	-	1394	400
1000	265	1000	1848	675	700	1945	320	1370	170	360	185	-	Ø22	-	1542	400
1100	290	1000	1988	675	700	2085	385	1370	170	360	185	-	Ø22	-	1542	400
1200	300	1000	2128	675	700	2225	430	1370	170	360	185	-	Ø22	-	1542	400
1300	325	1000	2268	675	700	2365	500	1370	170	360	185	-	Ø22	-	1542	400
1400	350	1000	2408	675	700	2500	570	1370	170	360	185	-	Ø22	-	1542	400
1500	375	1000	2548	675	700	2640	600	1370	170	360	185	-	Ø22	-	1542	400
1600	400	1000	2689	675	700	2785	675	1370	170	360	185	-	Ø22	-	1542	400
1700	450	1000	2829	675	700	2925	750	1370	170	360	185	-	Ø22	-	1542	400
1800	475	1200	2234	700	800	2330	500	1575	1067	450	135	-	Ø26 2 Holes	30 2 Slots	1745	400
1900	500	1200	2331	700	800	2430	550	1575	1067	450	135	-	Ø26 2 Holes	30 2 Slots	1745	400
2000	530	1200	2428	700	800	2525	600	1575	1067	450	135	-	Ø26 2 Holes	30 2 Slots	1745	400
2200	580	1200	2623	700	800	2720	675	1575	1067	450	135	-	Ø26 2 Holes	30 2 Slots	1745	400
2400	600	1200	2817	700	800	2915	685	1575	1050	450	250	140	Ø26	30	1745	400
2600	700	1200	3012	700	800	3110	755	1575	1050	450	250	140	Ø26	30	1745	400
2800	750	1200	3206	700	800	3300	830	1575	1050	450	250	140	Ø26	30	1745	400
3000	800	1400	2659	650	900	2755	535	1775	1250	550	250	140	Ø26	30	1946	400
3250	850	1400	2838	650	900	2835	620	1775	1250	550	250	140	Ø26	30	1946	400
3500	900	1400	3016	650	900	3110	710	1775	1250	550	250	140	Ø26	30	1946	400
3750	1000	1400	3195	650	900	3290	780	1775	1250	550	250	140	Ø26	30	1946	400
4000	1050	1400	3374	650	900	3470	860	1775	1250	550	250	140	Ø26	30	1946	400
4250	1100	1400	3552	650	900	3645	940	1775	1250	550	250	140	Ø26	30	1946	400
4500	1200	1400	3731	650	900	3825	1020	1775	1250	550	250	140	Ø26	30	1946	400
4750	1250	1400	3910	650	900	4005	1100	1775	1250	550	250	140	Ø26	30	1946	400
5000	1300	1600	3287	775	1000	3380	705	1980	1420	635	250	140	Ø26	30	2149	400
5250	1400	1600	3424	775	1000	3515	775	1980	1420	635	250	140	Ø26	30	2149	400
5500	1450	1600	3561	775	1000	3655	845	1980	1420	635	250	140	Ø26	30	2149	400
5750	1500	1600	3697	775	1000	3790	915	1980	1420	635	250	140	Ø26	30	2149	400
6000	1600	1600	3834	775	1000	3930	985	1980	1420	635	250	140	Ø26	30	2149	400
6250	1650	1600	3971	775	1000	4065	1055	1980	1420	635	250	140	Ø26	30	2149	400
6500	1700	1600	4108	775	1000	4205	1125	1980	1420	635	250	140	Ø26	30	2149	400
6750	1800	1600	4245	775	1000	4340	1195	1980	1420	635	250	140	Ø26	30	2149	400
7000	1850	1600	4381	775	1000	4475	1265	1980	1420	635	250	140	Ø26	30	2149	400
7250	1900	1600	4518	775	1000	4615	1335	1980	1420	635	250	140	Ø26	30	2149	400
7500	2000	1600	4655	775	1000	4750	1405	1980	1420	635	250	140	Ø26	30	2149	400
7750	2050	1725	4220	675	1060	4315	1050	2100	1530	690	350	200	Ø26	30	2174	300
8000	2100	1725	4337	675	1060	4435	1110	2100	1530	690	350	200	Ø26	30	2174	300
8250	2200	1725	4455	675	1060	4550	1170	2100	1530	690	350	200	Ø26	30	2174	300
8500	2250	1725	4573	675	1060	4670	1240	2100	1530	690	350	200	Ø26	30	2174	300
8750	2300	1725	4690	675	1060	4785	1290	2100	1530	690	350	200	Ø26	30	2174	300
9000	2400	1725	4808	675	1060	4905	1320	2100	1530	690	350	200	Ø26	30	2174	300
9250	2450	1725	4926	675	1060	5020	1380	2100	1530	690	350	200	Ø26	30	2174	300
9500	2500	1725	5043	675	1060	5140	1440	2100	1530	690	350	200	Ø26	30	2174	300
9750	2600	1725	5161	675	1060	5256	1500	2100	1530	690	350	200	Ø26	30	2174	300
10000	2700	1725	5279	675	1060	5375	1365	2100	1530	690	350	200	Ø26	30	2174	300
10500	2800	1725	5514	675	1060	5610	1480	2100	1530	690	350	200	Ø26	30	2174	300
11000	2900	1725	5749	675	1060	5845	1600	2100	1530	690	350	200	Ø26	30	2174	300
11500	3000	1725	5985	675	1060	6080	1700	2100	1530	690	350	200	Ø26	30	2174	300
12000	3100	1725	6220	675	1060	6315	1700	2100	1530	690	350	200	Ø26	30	2174	300
12500	3300	1725	6455	675	1060	6550	1815	2100	1530	690	350	200	Ø26	30	2174	300
13000	3400	1725	6691	675	1060	6790	1935	2100	1530	690	350	200	Ø26	30	2174	300
13500	3500	1725	6926	675	1060	7021	2050	2100	1530	690	350	200	Ø26	30	2174	300
14000	3700	1725	7162	675	1060	7260	2170	2100	1530	690	350	200	Ø26	30	2174	300
14500	3800	1725	7397	675	1060	7495	2300	2100	1530	690	350	200	Ø26	30	2174	300
15000	3900	1725	7632	675	1060	7730	2300	2100	1530	690	350	200	Ø26	30	2174	300



NOTE:

1. All dimensions are approximate and may vary slightly.
2. Ratio Controller supplied is wafer type, flanged end will be optional. Stainless Steel CF8 (SS304) is standard supply. Bronze or CF8M (SS316) is optional supply.
3. For space requirement of Bladder Tank, provision must be made for removal of internal piping and bladder. There are dimensions as marked and given in dimensional chart.
4. Manhole cover is not considered in standard supply and can be supplied at additional cost.
5. For tank exceeding shipping crate or container size, piping will be supplied in disassembled condition.
6. Level indicator is always supplied disassembled.
7. Large capacity Bladder Tank may require high roof or open roof for loading and unloading. Check with sales for details.
8. Optional sight glass level check may not indicate correct level with AR-AFFF foam concentrate.
9. Foam filling kit needs to be ordered separately.

LIMITED WARRANTY

3A KÖPÜKLÜ YANGIN KORUNUM SİSTEMLERİ SAN. VE TİC. LTD. ŞTİ. hereby referred to as 3A warrants to the original purchaser of the fire protection products manufactured by 3A and to any other person to whom such equipment is transferred, that such products will be free from defect in material and workmanship under normal use and care, for two (2) years from the date of shipment by 3A. Products or Components supplied or used by 3A, but manufactured by others, are warranted only to the extent of the manufacturer's warranty. No warranty is given for product or components which have been subject to misuse, improper installation, corrosion, unauthorized repair, alteration or un-maintained. 3A shall not be responsible for system design errors or improper installation or inaccurate or incomplete information supplied by buyer or buyer's representatives. 3A will repair or replace defective material free of charge, which is returned to our factory, transportation charge prepaid, provided after our inspection the material is found to have been defective at the time of initial shipment from our works. 3A shall not be liable for any incidental or consequential loss, damage or expense arising directly or indirectly from the use of the product including damages for injury to person, damages to property and penalties resulting from any products and components manufactured by 3A. 3A shall not be liable for any damages or labour charges or expense in making repair or adjustment to the product. 3A shall not be liable for any damages or charges sustained in the adaptation or use of its engineering data & services. In no event shall 3A's product liability exceed an amount equal to the sale price. The foregoing warranty is exclusive and in lieu of all other warranties and representation whether expressed, implied, oral or written, including but not limited to, any implied warranties or merchantability or fitness for a particular purpose. All such other warranties and representations are hereby cancelled.

NOTICE:

The equipment presented in this bulletin is to be installed in accordance with the latest publication standards of NFPA or other similar organisations and also with the provision of government codes or ordinances wherever applicable. The information provided by us is to the best of our knowledge and belief, and consist of general guidelines only. Site handling and installation control is not in our scope. Hence we give no guarantee for result and take no liability for damages, loss or penalties whatsoever, resulting from our suggestion, information, recommendation or damages due to our product. Product development is a continuous programme of 3A KÖPÜKLÜ YANGIN KORUNUM SİSTEMLERİ SAN. VE TİC. LTD. ŞTİ. and hence the right to modify any specification without prior notice is reserved with the company.

MODEL - 3A BTP WS & 3A BTP WSM

TECHNICAL DATA	
MODEL	Stainless Steel Construction:- 3A BTP WS & 3A BTP WSM
SIZE	65, 80, 100, 150 & 200 NB
MAX. SERVICE PRESSURE	14 Bar (200 PSI) 12.3 Bar (175 PSI) for FM
FACTORY HYDRO TEST PRESSURE	25 Kg./Sq.cm. (350 PSI)
MOUNTING	Between the flanges ANSI B16.5 - 150#
APPROVAL	FM Approved
FINISH	Red RAL 3001 or Natural Finish
ORDERING INFORMATION	Specify: a) Model & Size b) Minimum and Maximum Pressure and flow rate c) Induction Percentage d) Type of Foam Concentrate used

DESCRIPTION

Ratio Controller is used for proportioning foam concentrate into the water supply with a wide range of flow and pressure. The Ratio Controller is also used with Bladder Tank Proportioning System, Inline Balance Proportioning System and Skid Mounted Pump Balance Proportioning System.

SPECIFICATION

The Ratio Controller works on venturi principle. As the water flow passes through nozzle at the inlet of ratio controller, a low-pressure area is created between inlet nozzle and the down stream section called diffuser. This low-pressure area causes the foam concentrate to flow through a metering orifice at the concentrate inlet and into the low-pressure area.

As the system demand varies, the water jet through Ratio Controller increases or decreases, which in turn varies the pressure at the low-pressure area of the Ratio Controller. This affects the corresponding pressure across the foam concentrate-metering orifice. The system requires same pressure of water and concentrate in order to balance the proportioning system.



INSTALLATION

Ratio Controller Model 3A BTP WS is wafer style to be mounted in SCH40 pipe between two flanges. Flow direction arrow is marked on the Ratio Controller.

NOTE

- 1) A minimum of five pipe diameter of straight unobstructed pipe is required at upstream and down stream of each ratio controller.
- 2) Ratio Controller shall be installed between two ANSI 150# flanges with raised face or flat face. The gasket-stud & flanges shall be provided by the installer.
- 3) Provision shall be made in piping for removal of Ratio Controller.
- 4) The pipes on upstream & downstream side of the Ratio Controller must be adequately supported and no strain shall be imposed on Ratio Controller.
- 5) Ratio Controller is FM Approved with 3A YANGIN Bladder Tank, Refer to specific FM Approval data for more information.
- 6) Ratio Controller is FM Approved for 2.1 to 12 bar pressure.
- 7) For Flow data, when used with Inline Balance pressure proportioner, contact 3A YANGIN Sales.

RATIO CONTROLLER (WAFER STYLE - 3A BTP SERIES)

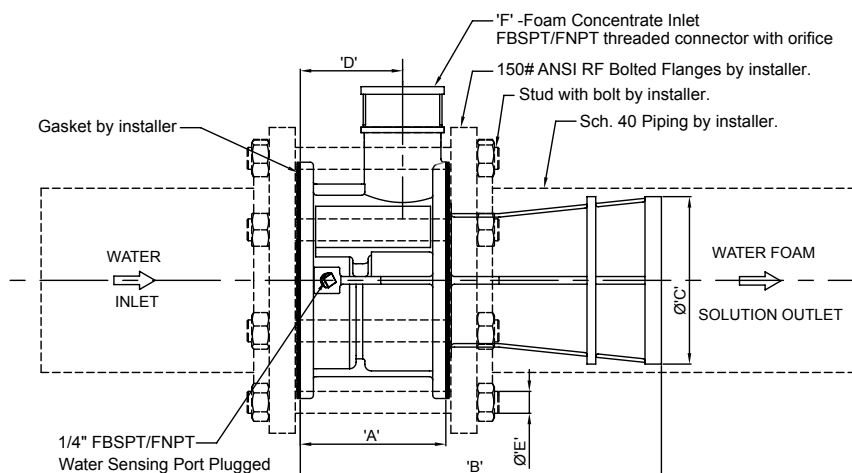

DIMENSIONS

Size	Approximate Dimensions (in mm)					
	'A'	'B'	Ø 'C'	'D'	Ø 'E'	'F'
8"	130	340	Ø200	80	M20 X 240 LONG	2" BSP (F)/NPT (F)
6"	133	330	Ø152	93.5	M20 X 230 LONG	2" BSP (F)/NPT (F)
4"	126	266	Ø101	90	M16 X 220 LONG	1-1/2" BSP (F)/NPT (F)
3"	107.5	190	Ø76	82.5	M16 X 200 LONG	1-1/2" BSP (F)/NPT (F)
2-1/2"	80	190	Ø61.7	55	M16 X 170 LONG	1" BSP (F)/NPT (F)

FM APPROVED RATIO CONTROLLER FLOW RANGE (LPM)

Size	Model		FM Approved	
	Wafer Style	Flange Style	AFFF 3%	AR-AFFF 3X3%
65 NB	3A BTP WS	----	102 TO 1590	500 TO 1030
	3A BTP WSM	----	----	165 TO 528
80 NB	3A BTP WS	----	290 TO 2990	----
	3A BTP WSM	----	----	820 TO 3080
100 NB	3A BTP WS	----	600 TO 6050	1810 TO 6140
150 NB	3A BTP WS	----	1200 TO 11460	5000 TO 12300
	3A BTP WSM	---	---	---
200 NB	3A BTP WS	---	---	---

INLET PRESSURE VS FOAM SOLUTION FLOW FM APPROVED, MODEL 3A BTP WS (FOAM CONCENTRATE: AFFF 3%)

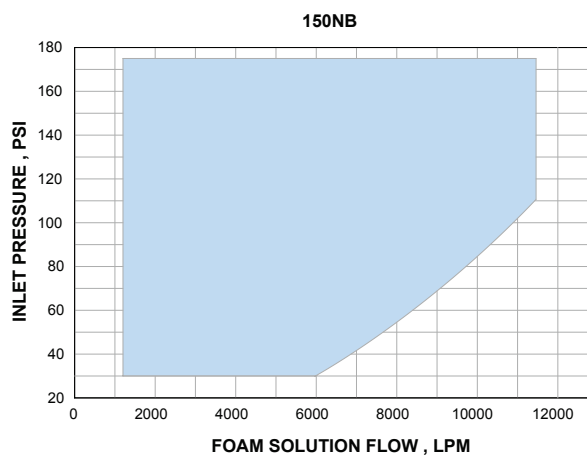
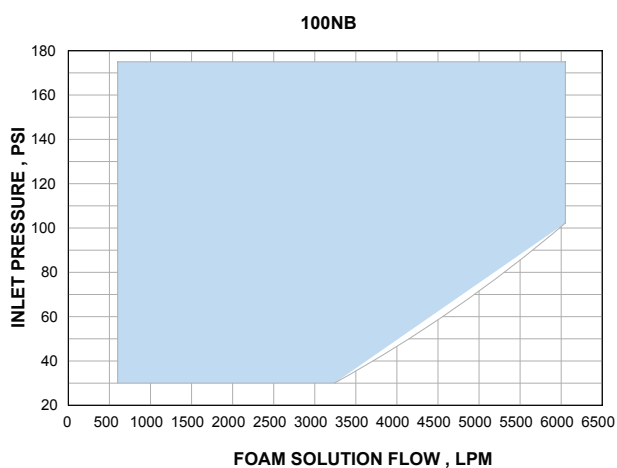
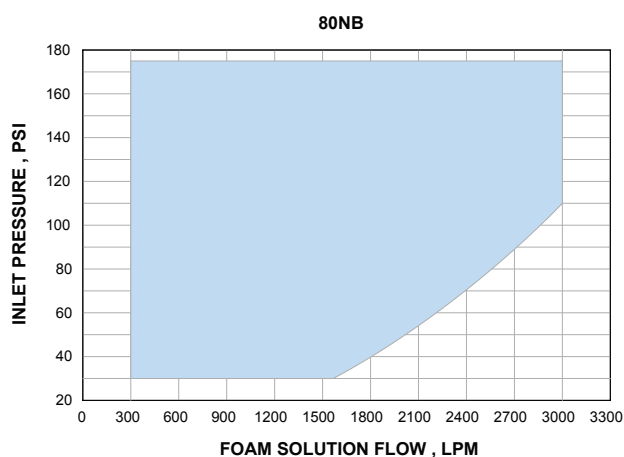
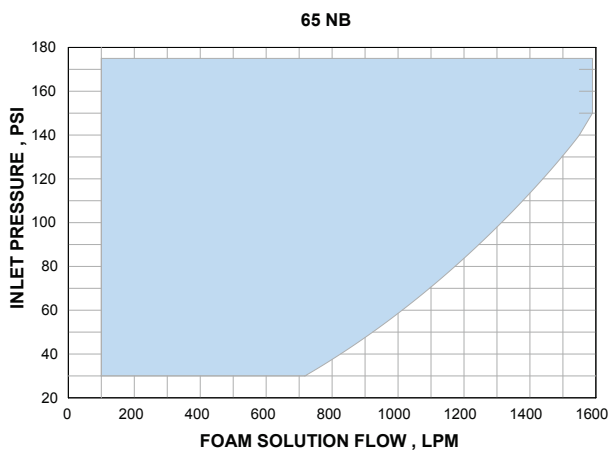

INLET PRESSURE VS FOAM SOLUTION FLOW FM APPROVED (FOAM CONCENTRATE: AR-AFFF 3X3%)

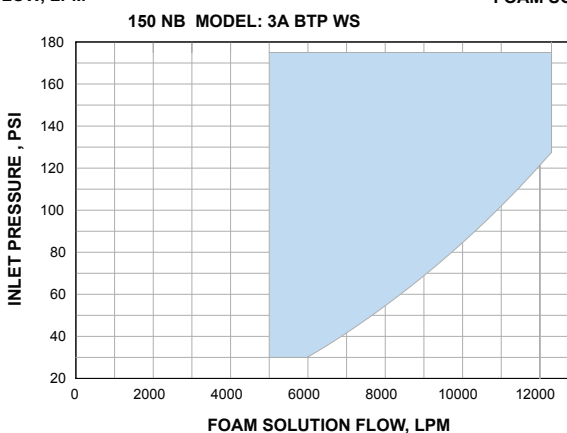
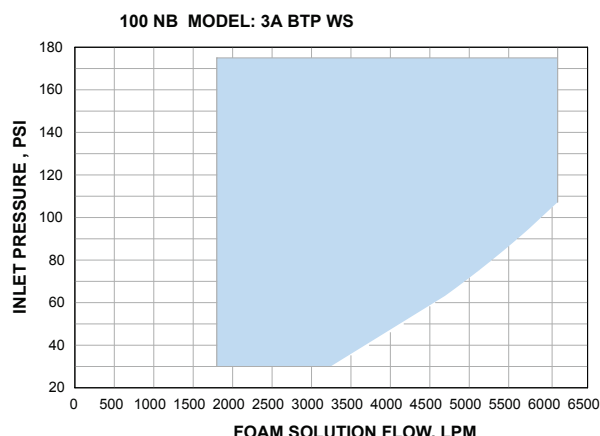
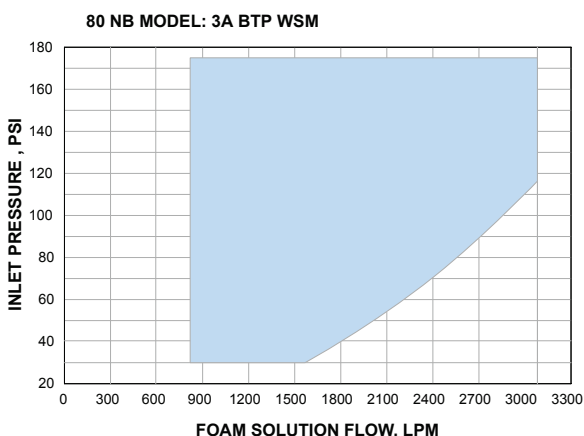
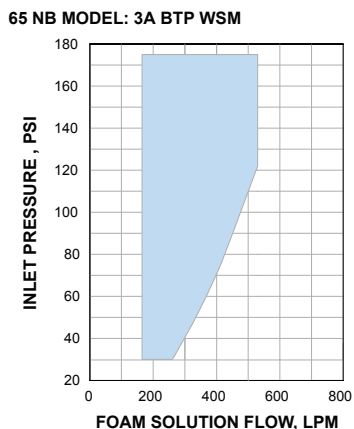
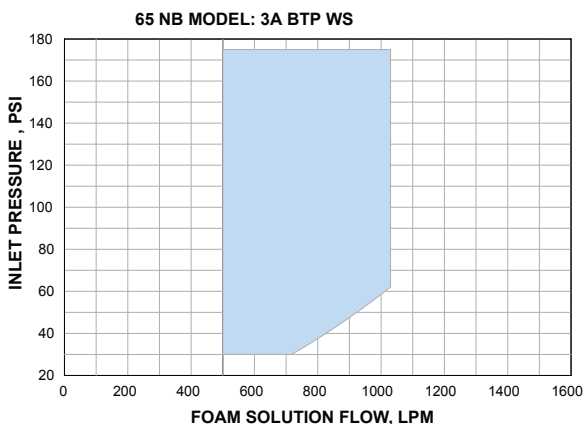

FLOW VS PRESSURE LOSS

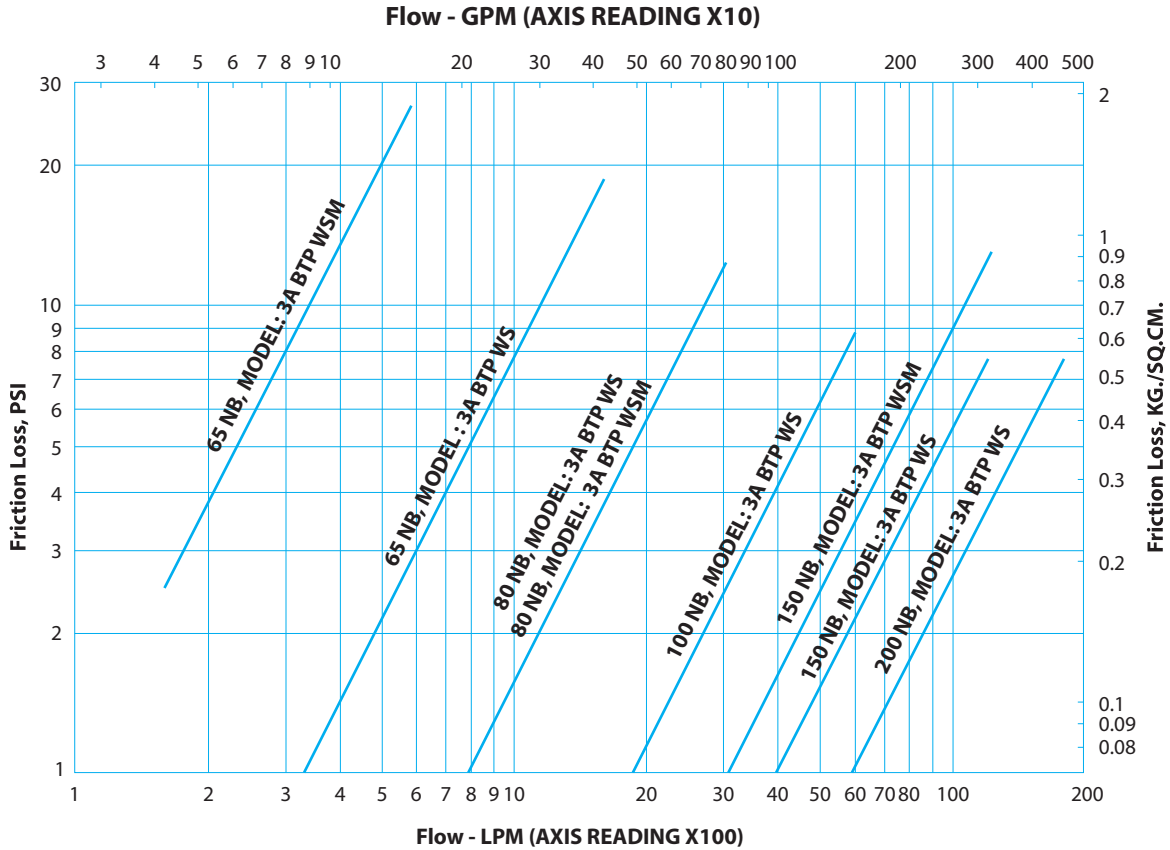

LIMITED WARRANTY

3A KÖPÜKLÜ YANGIN KORUNUM SİSTEMLERİ SAN. VE TİC. LTD. ŞTİ. hereby referred to as 3A YANGIN warrants to the original purchaser of the fire protection products manufactured by 3A YANGIN and to any other person to whom such equipment is transferred, that such products will be free from defect in material and workmanship under normal use and care, for two (2) years from the date of shipment by 3A YANGIN. Products or Components supplied or used by 3A YANGIN, but manufactured by others, are warranted only to the extent of the manufacturer's warranty. No warranty is given for product or components which have been subject to misuse, improper installation, corrosion, unauthorized repair, alteration or un-maintained. 3A YANGIN shall not be responsible for system design errors or improper installation or inaccurate or incomplete information supplied by buyer or buyer's representatives. 3A YANGIN will repair or replace defective material free of charge, which is returned to our factory, transportation charge prepaid, provided after our inspection the material is found to have been defective at the time of initial shipment from our works. 3A YANGIN shall not be liable for any incidental or consequential loss, damage or expense arising directly or indirectly from the use of the product including damages for injury to person, damages to property and penalties resulting from any products and components manufactured by 3A YANGIN. 3A YANGIN shall not be liable for any damages or labour charges or expense in making repair or adjustment to the product. 3A YANGIN shall not be liable for any damages or charges sustained in the adaptation or use of its engineering data & services. In no event shall's product liability exceed an amount equal to the sale price. The foregoing warranty is exclusive and in lieu of all other warranties and representation whether expressed, implied, oral or written, including but not limited to, any implied warranties or merchantability or fitness for a particular purpose. All such other warranties and representations are hereby cancelled.

NOTICE:

The equipment presented in this bulletin is to be installed in accordance with the latest publication standards of NFPA or other similar organisations and also with the provision of government codes or ordinances wherever applicable.

The information provided by us is to the best of our knowledge and belief, and consist of general guidelines only. Site handling and installation control is not in our scope. Hence we give no guarantee for result and take no liability for damages, loss or penalties whatsoever, resulting from our suggestion, information, recommendation or damages due to our product.

Product development is a continuous programme of 3A KÖPÜKLÜ YANGIN KORUNUM SİSTEMLERİ SAN. VE TİC. LTD. ŞTİ. and hence the right to modify any specification without prior notice is reserved with the company.



3A CV

TECHNICAL DATA	
MODEL	3A CV
SIZE	25, 40 & 50 NB
FACTORY HYDROTESTED	25 Kg./sq.cm.
OPERATING PRESSURE	MIN 2.1 Kg/SqCm (30 PSI) MAX 12.3 Kg/SqCm (175 PSI)
MATERIAL	Stainless Steel 304 standard supply. Optional 304L, 316 or 316L
INLET & OUTLET CONNECTION	Flanged end to ANSI B16.5#150RF
APPROVALS	Model CV is FM Approved with Foam Bladder Tank System of 3A YANGIN
VISUAL	Provided with Model CV only, Red for closed & Yellow for open
REMOTE INDICATION	Provided with Model CV only Through limit switch box, Ex.Proof, Class-1, Group-C&D, IIA, IIB, & C
PRESSURE SENSING HOSE	Teflon tube with Stainless Steel braided cover
TRIM CONNECTION	Brass / Stainless Steel
FINISH	RED RAL 3001
ORDERING INFORMATION	Specify Model number & Size



SELECTION OF FOAM CONCENTRATE CONTROL VALVE

HD Proportioner	Foam Concentrate Control Valve Size
65 NB	25 NB
80 NB	40 NB
100 NB	40 NB
150 NB	50 NB

APPLICATION

Foam concentrate control valve is designed for use in bladder tank foam system or inline balance pressure proportioning system. The valve opens automatically when water supply is established through the inlet pipe of ratio controller of bladder tank or in the inline balance pressure proportioning system. The valve opens at minimum of 2.1 Kg./sq.cm. (30 psi) water pressure. No electric power is required to operate the valve.

SPECIFICATION

The foam concentrate control valve utilizes water as the medium to open the valve. A manual override facility is provided to open the valve. In normal condition the valve remains in closed position. When, a minimum water pressure of 2.1 Kg./sq.cm. (30 psi) is established the valve opens and closing of the valve is manual.

Visual indication as well as electric contact is provided for remote indication for open and closed position only in Model CV.

MODEL - CV

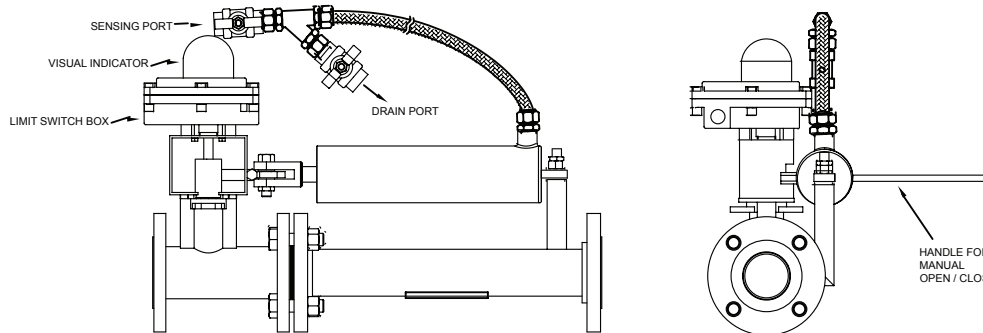

ELECTRICAL CONNECTION DIAGRAM

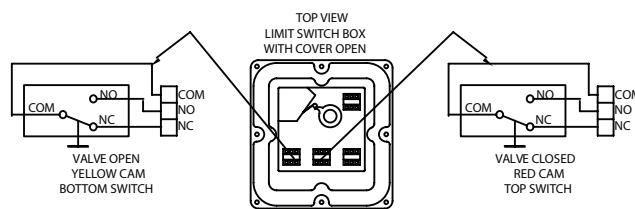

To close the valve:

1. Close Sensing port valve.
2. Open the drain port valve and all the water to drain.
3. Manual Operation handle and to be pulled till valve is fully closed.
4. Close the drain port valve.
5. Open the Sensing port valve.

NOTE: Valve can be opened manually by pulling the manual handle till the valve is fully open, after opening of drain valve & closing of Sensing port valve.

TYPICAL INSTALLATION OF FOAM CONCENTRATE CONTROL VALVE

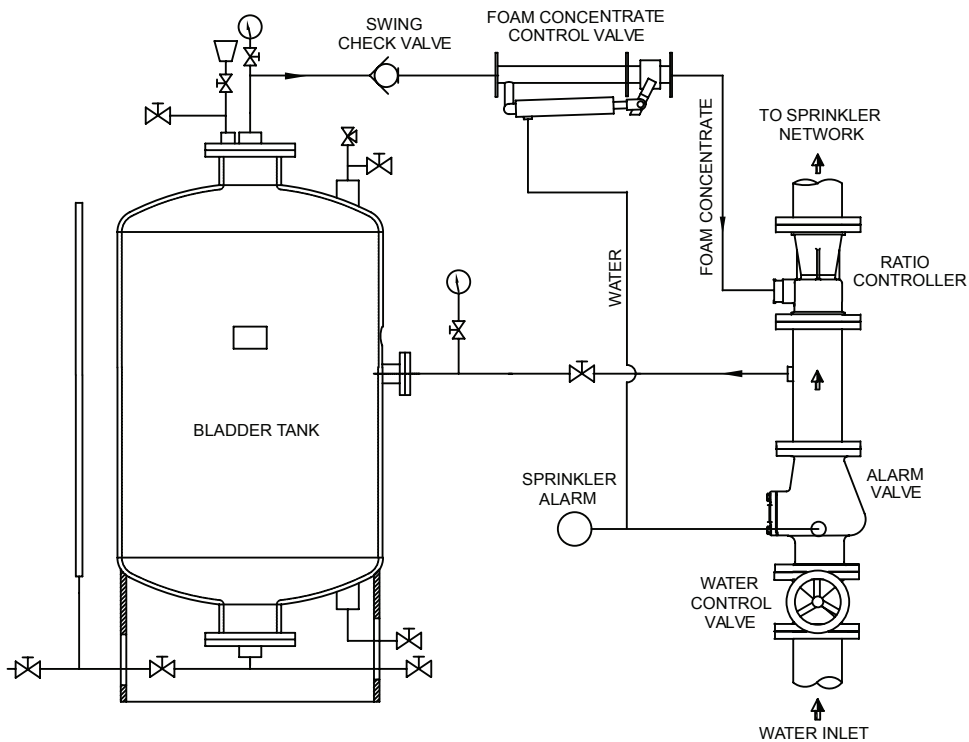
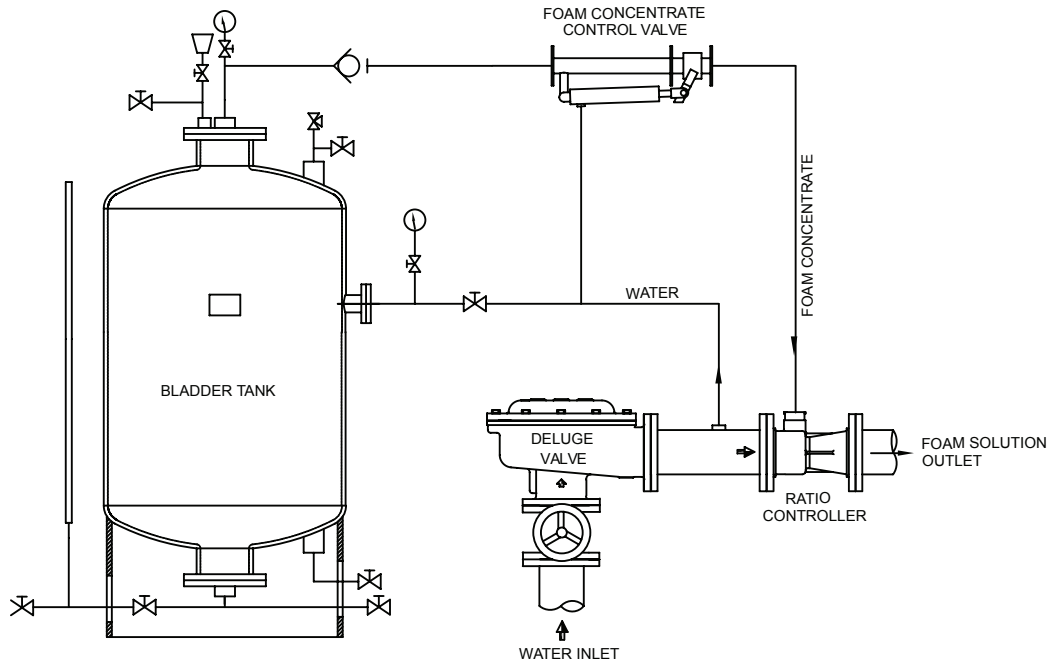

INSPECTION AND MAINTENANCE

A qualified and trained person must commission the system. After few initial successful tests, an authorised person must be trained to perform the inspection and testing of the system, at least once in a week. The inspection should verify that all the control valves are in their proper position as per the system requirement and no damage has taken place to any component. The foam concentrate control valve/system must be operated at least once in six weeks. The total system should be fully tested at least once in a year as per NFPA / TAC manual or in accordance to the guidelines of the organisation having local jurisdiction.

It is advised to have following minimum tests and inspection:

- 1) Manually operate the valve two to three times at least once in two months.
- 2) Fully operate with water pressure at least once in a year.

LIMITED WARRANTY

3A KÖPÜKLÜ YANGIN KORUNUM SİSTEMLERİ SAN. VE TİC. LTD. ŞTİ. hereby referred to as 3A YANGIN warrants to the original purchaser of the fire protection products manufactured by 3A YANGIN and to any other person to whom such equipment is transferred, that such products will be free from defect in material and workmanship under normal use and care, for two (2) years from the date of shipment by 3A YANGIN. Products or Components supplied or used by 3A YANGIN, but manufactured by others, are warranted only to the extent of the manufacturer's warranty. No warranty is given for product or components which have been subject to misuse, improper installation, corrosion, unauthorized repair, alteration or un-maintained. 3A YANGIN shall not be responsible for system design errors or improper installation or inaccurate or incomplete information supplied by buyer or buyer's representatives. 3A YANGIN will repair or replace defective material free of charge, which is returned to our factory, transportation charge prepaid, provided after our inspection the material is found to have been defective at the time of initial shipment from our works. 3A YANGIN shall not be liable for any incidental or consequential loss, damage or expense arising directly or indirectly from the use of the product including damages for injury to person, damages to property and penalties resulting from any products and components manufactured by 3A YANGIN. 3A YANGIN shall not be liable for any damages or labour charges or expense in making repair or adjustment to the product. 3A YANGIN shall not be liable for any damages or charges sustained in the adaptation or use of its engineering data & services. In no event shall 3A YANGIN's product liability exceed an amount equal to the sale price. The foregoing warranty is exclusive and in lieu of all other warranties and representation whether expressed, implied, oral or written, including but not limited to, any implied warranties or merchantability or fitness for a particular purpose. All such other warranties and representations are hereby cancelled.

NOTICE :

The equipment presented in this bulletin is to be installed in accordance with the latest publication standards of NFPA or other similar organisations and also with the provision of government codes or ordinances wherever applicable.

The information provided by us is to the best of our knowledge and belief, and consist of general guidelines only. Site handling and installation control is not in our scope. Hence we give no guarantee for result and take no liability for damages, loss or penalties whatsoever, resulting from our suggestion, information, recommendation or damages due to our product.

Product development is a continuous programme of 3A KÖPÜKLÜ YANGIN KORUNUM SİSTEMLERİ SAN. VE TİC. LTD. ŞTİ. and hence the right to modify any specification without prior notice is reserved with the company.



3A AFFF 3-C6

DESCRIPTION

3A AFFF 3-C6 is a synthetic Aqueous Film Forming Foam concentrate, specially formulated with new generation C6 based fluorinated surfactants which are environmentally safer.

3A AFFF 3-C6 is formulated with C6 based fluorinated surfactants, hydrocarbon surfactants and solvents. It produces a thin yet strong film on Hydrocarbon fuel surface, sealing the surface and preventing fuel vapour release.

The foam spreads rapidly on fuel surface due to positive spreading provided by fluoro surfactants while the foam blanket excludes oxygen from the fuel surface and provides cooling effect leading to fast flame knockdown and extinguishment.

3A AFFF 3-C6 is intended for use at 3% solution in fresh, sea/salt or hard water.

APPLICATION

3A AFFF 3-C6 is suitable for Class B fires of hydrocarbons like crude oil, gasoline, diesel, aviation fuel, kerosene etc. in sectors like Refineries, Tank Terminals, Process Areas, Power Plants, Port Terminals, Airports, Flammable Liquid Containment Area, Offshore and Onshore Installations etc.

3A AFFF 3-C6 can also be used as a wetting agent in combating fires in Class A materials such as wood, paper and tyres.

PROPORTIONING

3A AFFF 3-C6 can be used with all types of Foam Proportioning & Discharge Devices such as Portable and Fixed Foam Proportioners, Branch Pipes, Foam Bladder tanks, Ratio Controllers and around-the-pump proportioners, Spray Fog Nozzles, Monitors, Foam Makers, Foam Chambers, Foam Pourers, Rim seal Foam Pourers, Foam Sprinklers etc.

APPROVALS AND LISTINGS

FM Approved

STORAGE AND SHELF LIFE

It has a maximum shelf life of 15 years when stored in its original container. Storage temperature should be below 49°C. The product can withstand intermittent short time exposure up to 60°C. Ensure that the containers are not directly exposed to sunlight and heat. It is unaffected by freeze/thaw cycles.

COMPATIBILITY

3A AFFF 3-C6 is compatible with dry powders and other equivalent foams. It is suitable for twin agent application systems, separately or in combination.



TYPICAL PROPERTIES

PARAMETERS	VALUES
Appearance	Clear liquid to Amber Colour liquid
Specific Gravity @20°C (68°F)	1.02 ± 0.02
pH @ 20°C (68°F)	8.0 ± 1.0
Viscosity @ 20°C (68°F)	<2cSt
Pour Point*	Flows at -2°C
Expansion **	>7
25% Drainage **	>2 min 15 sec

NOTE

* Available in Freeze Protected Type

** Value depends equipment used and system parameters

ENVIRONMENTAL INFORMATION

Being based on C6 fluoro surfactants, 3A AFFF 3-C6 is environmentally safer and low toxic to the aquatic organisms. It is bio-degradable.

Local regulations should be complied with for discharge into common drainage/sewage systems.

Refer MSDS for additional information.

PACKAGING

The product is available in 20L Jerry Cans, 200L Drums, 1000L Tote and bulk packing.

3A AR-AFFF 3X3-C6

DESCRIPTION

3A AR-AFFF 3X3-C6 is an Alcohol Resistant Aqueous Film Forming Foam concentrate, specially formulated with new generation C6 based fluorinated surfactants which are environmentally safer.

3A AR-AFFF 3X3-C6 is formulated with C6 based fluoro surfactants, hydrocarbon surfactants, polysaccharides and solvents. It produces thin yet strong aqueous film on hydrocarbon fuel surface, sealing the surface and preventing fuel vapour release.

The foam spreads rapidly on fuel surface due to positive spreading provided by fluoro surfactants while the foam blanket excludes oxygen from the fuel surface and provides cooling effect leading to fast flame knockdown and extinguishment.

Polysaccharide film is produced when the foam solution comes in contact with a water miscible polar solvent. This polymer film acts as raft to support the foam blanket on the surface of the polar fuel. Foam blanket cuts off oxygen from fuel surface and cools it thereby providing fast knockdown and fire extinguishment.

3A AR-AFFF 3X3-C6 is intended for use at 3% solution in fresh, sea/salt or hard water for both hydrocarbon and polar solvents fires.

APPLICATION

3A AR-AFFF 3X3-C6 is suitable for Class B fires of Hydrocarbons like crude oil, gasoline, diesel, aviation fuel, kerosene etc. and polar solvents like alcohols, ketones, esters, acetates etc. It is also recommended for aromatic hydrocarbon fires of benzene, xylene, toluene & their derivatives.

3A AR-AFFF 3X3-C6 can also be used as a wetting agent in combating fires in Class A materials such as wood, paper, and tyres.

PROPORTIONING

3A AR-AFFF 3X3-C6 can be used with various types of Foam Proportioning & Discharge Devices such as Portable and Fixed Foam Proportioners, Branch Pipes, Foam Bladder Tanks, Ratio Controllers and Around-the-Pump Proportioners, Spray Fog Nozzles, Monitors, Foam Makers, Foam Chambers, Foam Pourers, Rim Seal Foam Pourers, Foam-Water Sprinklers etc.

APPROVALS AND LISTINGS

FM Approved

COMPATIBILITY

3A AR-AFFF 3X3-C6 is compatible with dry powders and other equivalent foams.



TYPICAL PROPERTIES

PARAMETERS	VALUES
Appearance	Viscous liquid (Amber Colour)
Specific Gravity @20°C (68°F)	1.02 ± 0.02
pH @ 20°C (68°F)	8.0 ± 1.0
Viscosity @ 20°C (68°F), #4, 60 rpm	1200 ± 500 cPs
Pour Point*	Flows at 0°C
Expansion **	>7
25% Drainage **	>5 min 30 secs

* Also available in Freeze Protected Type

** Value depends on equipment used and system parameters

STORAGE AND SHELF LIFE

It has a shelf life of 10 years when stored in its original container. Storage temperature should be below 49°C. The product can withstand intermittent short time exposure up to 60°C. Ensure that the containers are not directly exposed to sunlight and heat. It is unaffected by freeze/thaw cycles. Refer Storage Conditions for additional information on storage.

ENVIRONMENTAL INFORMATION

Being based on C6 fluoro surfactants, 3A AR-AFFF 3X3-C6 is environmentally safer and low toxic to the aquatic organisms. It is bio-degradable.

Local regulations should be complied with for discharge into common drainage/sewage systems.

Refer MSDS for additional information.

PACKAGING

The product is available in 20L Jerry Cans, 200L Drums, 1000 L Tote and bulk packing.

LIMITED WARRANTY

3A KÖPÜKLÜ YANGIN KORUNUM SİSTEMLERİ SAN. VE TİC. LTD. ŞTİ. hereby referred to as 3A warrants to the original purchaser of the fire protection products manufactured by 3A and to any other person to whom such equipment is transferred, that such products will be free from defect in material and workmanship under normal use and care, for two (2) years from the date of shipment by 3A. Products or Components supplied or used by 3A, but manufactured by others, are warranted only to the extent of the manufacturer's warranty. No warranty is given for product or components which have been subject to misuse, improper installation, corrosion, unauthorized repair, alteration or un-maintained. 3A shall not be responsible for system design errors or improper installation or inaccurate or incomplete information supplied by buyer or buyer's representatives. 3A will repair or replace defective material free of charge, which is returned to our factory, transportation charge prepaid, provided after our inspection the material is found to have been defective at the time of initial shipment from our works. 3A shall not be liable for any incidental or consequential loss, damage or expense arising directly or indirectly from the use of the product including damages for injury to person, damages to property and penalties resulting from any products and components manufactured by 3A. 3A shall not be liable for any damages or labour charges or expense in making repair or adjustment to the product. 3A shall not be liable for any damages or charges sustained in the adaptation or use of its engineering data & services. In no event shall 3A's product liability exceed an amount equal to the sale price. The foregoing warranty is exclusive and in lieu of all other warranties and representation whether expressed, implied, oral or written, including but not limited to, any implied warranties or merchantability or fitness for a particular purpose. All such other warranties and representations are hereby cancelled.

NOTICE :

The equipment presented in this bulletin is to be installed in accordance with the latest publication standards of NFPA or other similar organisations and also with the provision of government codes or ordinances wherever applicable.

The information provided by us is to the best of our knowledge and belief, and consist of general guidelines only. Site handling and installation control is not in our scope. Hence we give no guarantee for result and take no liability for damages, loss or penalties whatsoever, resulting from our suggestion, information, recommendation or damages due to our product.

Product development is a continuous programme of 3A KÖPÜKLÜ YANGIN KORUNUM SİSTEMLERİ SAN. VE TİC. LTD. ŞTİ. and hence the right to modify any specification without prior notice is reserved with the company.



ISO 9001:2015

ISO 10002:2018

ISO 14001:2015



3A K p kl  Yangın Korunum Sistemleri San. ve Tic. Ltd. Őti.
K lt r Mah. Efil Sk. No:2/414 • Tatvan - Bitlis / T rkiye • Tel: 0212 320 16 86
E-mail : info@3ayangin.com.tr • www.3ayangin.com.tr